

ITEM NO.	PART NUMBER	DESCRIPTION	QTY.
1	Base		1
2	3.00 or 4.00 Shoulder Base Insert		1
3	3/8 x 16 Threaded Insert		2
4	12SWS3500 Shoulder Washer		4
5	3/8 x 16 x 1.5 Button Head Fastener		2
6	3/8 Locking Washer		2
7	Rubber Ring	Blue Sea Cable Clam PN: 1003	1
8	Cable Clam Base	Blue Sea Cable Clam PN: 1003	1
9	Cable Clam Top	Blue Sea Cable Clam PN: 1003	1
10	Rubber Cable Plug	Blue Sea Cable Clam PN: 1003	1
11	8-32 .625 inch machine screw		4
12	8-32 1 inch machine screw		4
13	.25 Oval Head Fastener	Not Included	4

PYI INC.
 12532 Beverly Park Rd.
 Lynnwood, WA 98037
 1-800-523-7558
 www.pyiinc.com

PROPRIETARY AND CONFIDENTIAL
 THE INFORMATION CONTAINED IN THIS DRAWING IS THE SOLE PROPERTY OF PYI, INC. ANY REPRODUCTION IN PART OR AS A WHOLE WITHOUT THE WRITTEN PERMISSION OF PYI, INC. IS PROHIBITED.

		DIMENSIONS ARE IN INCHES TOLERANCES: FRACTIONAL ± ANGULAR: MACH ± BEND ± TWO PLACE DECIMAL ± THREE PLACE DECIMAL ±
		MATERIAL
NEXT ASSY	USED ON	FINISH
APPLICATION		DO NOT SCALE DRAWING

	NAME	DATE
DRAWN		
CHECKED		
ENG APPR.		
MFG APPR.		
Q.A.		
COMMENTS:		

PYI, INC.

**RM-3AB 3" POLE
 RM-4AB 4" POLE**

SIZE	DWG. NO.	REV.
A	SWIVEL POLE MOUNT	
SCALE:1:8	WEIGHT:	SHEET 1 OF 1

Cableclam

Features

- Weatherproof material (Innolastic) without removing surmounture
- Have the sequence of removing and replacing surmounture
- Avoid your surmounture related to removing factory surmounture.

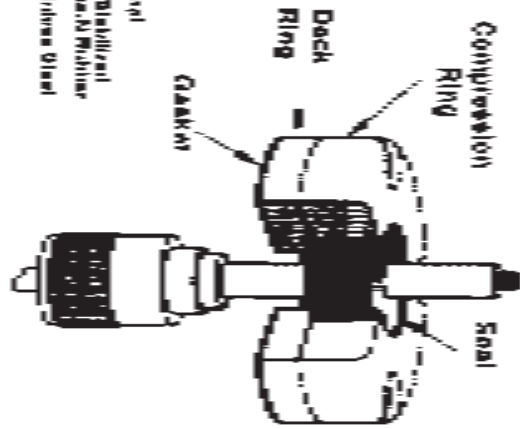

Cableclam Installation Instructions

- 1 Drill the seal with a sharp drill the same size as the hole. Keep the hole wet during drilling. The hole will be slightly smaller than the cable inserting a tight fit.
- 2 Use a sharp screw knife to cut the seal from the edge to the center hole.
- 3 Position the dash ring on the seal using the flat head screw driver and push it out.
- 4 Slip the compression ring on to the cable. Spread over the seal with and insert the cable. Press the seal into the compression ring.
- 5 Remove the compression ring to the dash ring. Tightening each of the pin head screws a few turns at a time. Take care not to over-tighten the screws.



Blue Sea Systems Inc.
 428 Bayville Drive • Millington, VA 20228 USA
 Phone (540)997-94-1700 • Fax (540)794-1700 • WWW.BLUOSEA.COM

Attaching Tube to Swivel Base

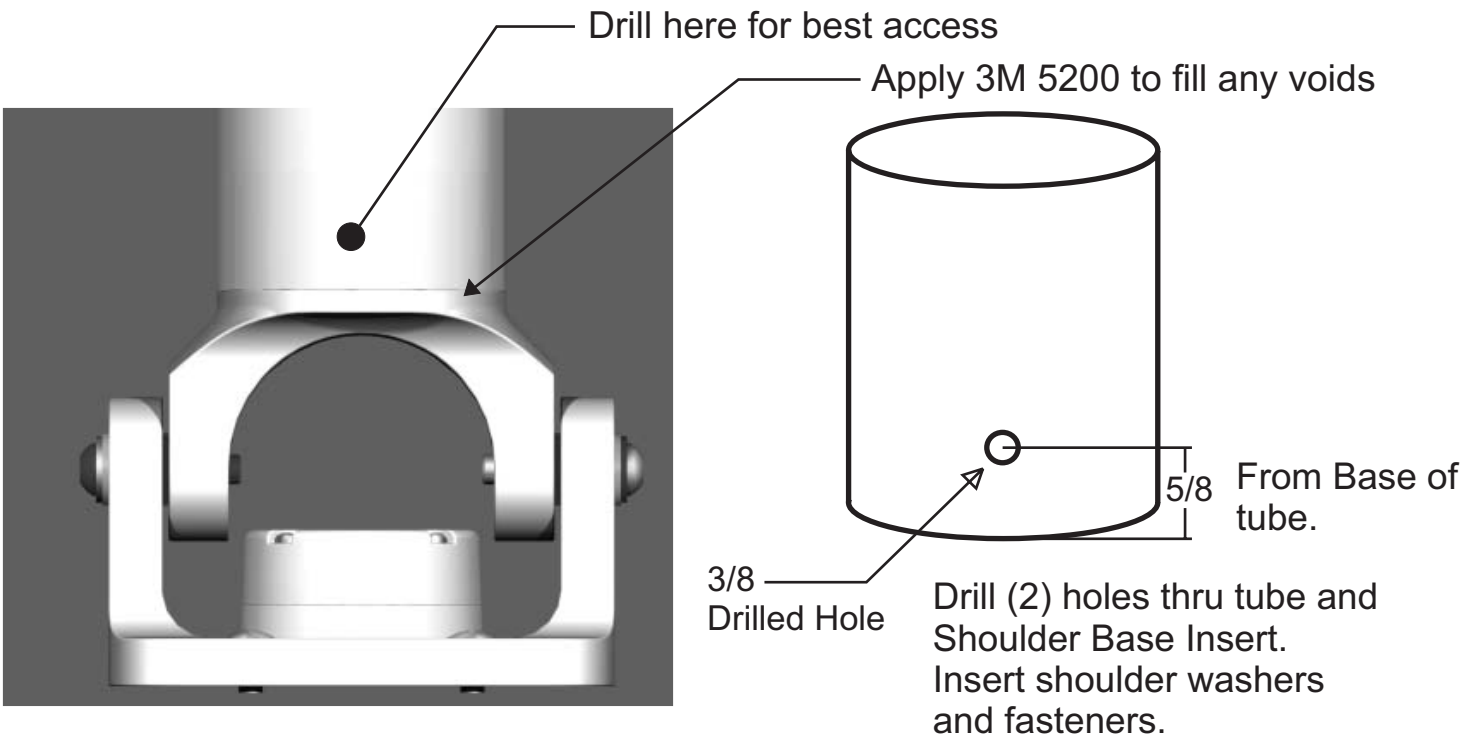

Disassemble Shoulder Base Insert from the Base unit. Mark and drill a 3/8 hole through the tube and Shoulder Base Insert. Insert shoulder washer and 1/4-20 Button Head fastener. On the inside of tube add nylon washer and nylock nut. Tighten assembly with 7/16 wrench and allen wrench. If necessary, apply a small bead of 3M 5200 Marine Adhesive Sealant between the tube and pole top. Reassemble Shoulder Base Insert to Base unit.