

Tiller arm specification form

Version 2.1

Tiller arm dimensioning

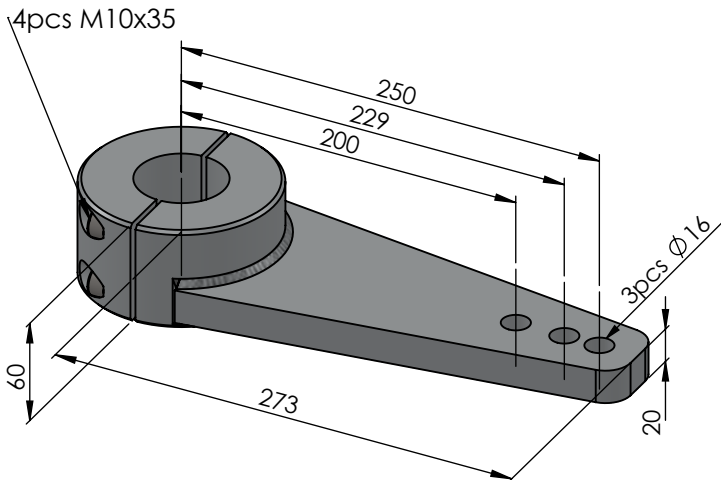

All tiller arm pilot bore is $\varnothing 25\text{mm}$

Bore diameter = _____ mm
 For no bore (pilot bore $\varnothing 25\text{mm}$) please cross this box

Please select the tillerarm by crossing the correct box

Bore diam.	Tillerarm	Cross box
25 - 50 mm	TLJ050	<input type="checkbox"/>
25 - 75 mm	TLJ075	<input type="checkbox"/>
28 - 100 mm	TLJ100	<input type="checkbox"/>
28 - 125 mm	TLJ125	<input type="checkbox"/>

TLJPIN16

16mm pin for tiller lever / draglink.
 (TLJPIN16 is not included in tiller lever)

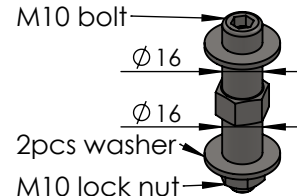

To include a 16mm tiller pin, please cross the box below

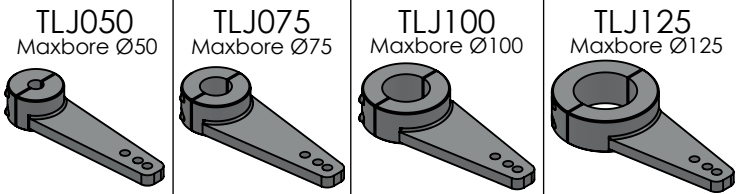

Special hole in tillerarm, please cross this box

Distance from center on rudderstock (L) = _____ mm

Size of hole in tillerarm (S) = \varnothing _____ mm

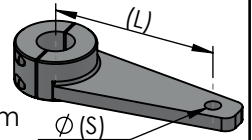

Opportunities of tiller arm locking mechanism's

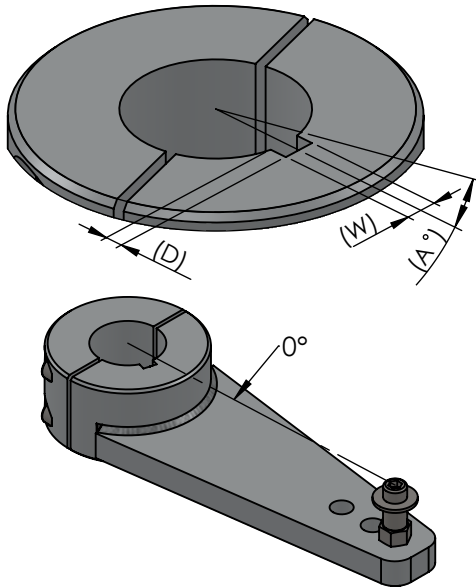

If a key is present, please specify dimensions below

Key width (W) = _____ mm

Key depth (D) = _____ mm

Key angle (A°) = _____ °

No keyway:

Keyway dimensions specified by: ((A°) from 0° and clockwise around) ((W) is key width in mm)((D) is keyway depth in mm)

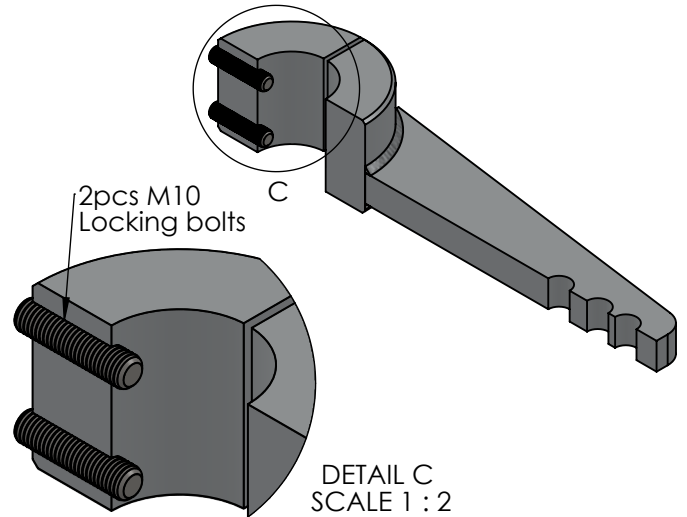

If no key is present, please cross the following box to include 2pcs off M10 locking bolts

Special requirements / comments