



QUALITY MARINE
EQUIPMENT SINCE 1981

PYI HOSE CLAMPS

Worm Gear Hose Clamps For 1/3" to 7 1/4" Hoses





TABLE OF CONTENTS

- 2 General PYI Hose Clamp Information
- 3 Worm Gear Hose Clamps
- 4 Worm Gear Hose Clamp Specifications
- 5 Clamp Jacket
- 6 Product Cross Reference Guide
- 6 Hose Clamp Accessories

PYI HOSE CLAMPS

RELIABLE

PYI Hose Clamps are manufactured entirely out of 316L stainless steel giving them excellent resistance to corrosive chemicals and acids that could limit the life of other metals. Whether used in a marine environment, industrially or around the house, the PYI Hose Clamp will keep any hose secure in some of the harshest environments.

DURABLE & STABLE CLAMPING FORCE

The PYI Hose Clamp utilizes a durable one-piece double locked screw cage design that is formed from a single piece of 316L stainless steel which is capable of withstanding high tightening torque and internal hose pressure. Our Hose Clamps can be hand tightened up to 135 in/lbs. without the screw slipping or distorting the screw cage during its installation and use, providing a reliable, strong and stable clamping force, as well as a long-lasting hold that is ideal for most demanding applications.

FOR ALL HOSE TYPES

By rolling the edges and removing perforations and ribs on the inside portion of the embossed hose band, the PYI Hose Clamp can be used on the softest hoses without worry of damage to the underlying surface during installation and throughout its use.

ENTIRELY 316L STAINLESS STEEL

316L stainless steel is the metal of choice for a marine grade hose clamp due to its superior resistance to the corrosive action of saltwater, deicing salts, industrial chemicals and acids. 316L utilizes a higher percentage of molybdenum, chromium and nickel than lower grade alloys. The addition of these elements not only improves the corrosion resistance of the material but also provides a greater creep resistance, a stronger stress-to-rupture and a higher tensile strength at elevated temperatures.

QUALITY AT EVERY LEVEL OF MANUFACTURING

PYI Hose Clamps are manufactured in a facility that is ISO 9001:2015 and Bureau Veritas certified and kitemarked to BS 5315:1991.

BENEFITS OF USING 316L STAINLESS STEEL

	316 STAINLESS
APPLICATIONS	
Automotive	•
Farm	•
Food	•
Garden	•
Heavy Duty	•
Home	•
Industrial	•
Marine	•
Medical	•
Plumbing	•
Forced Air	•
CHARACTERISTICS	
High Corrosion Resistance	•
PROPERTIES	
Material is Non-Magnetic	•

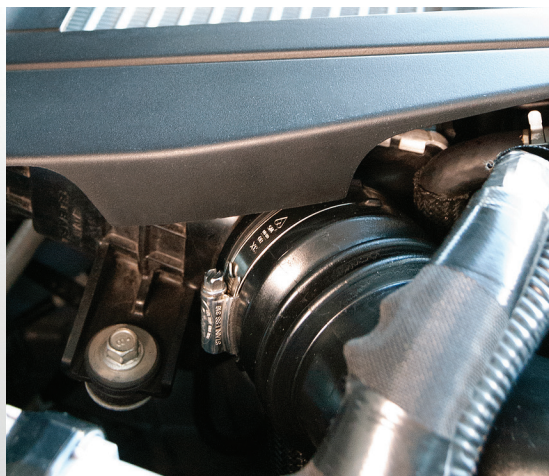
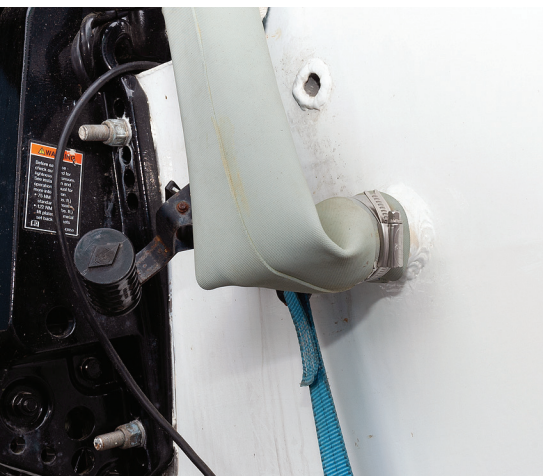

WORM GEAR HOSE CLAMPS



NON-PERFORATED



ROLLED EDGE



7mm
SLOTTED HEX HEAD



500°C MAX
OPERATING TEMP



CORROSION
RESISTANT 316L

- Non-perforated worm drive to increase strength and limit corrosion.
- Rolled edges to protect the hose from abrasion or cuts.
- 316L stainless steel construction that provides a high degree of corrosion resistance.
- One-piece screw cage capable of withstanding high tightening torque.
- The PYI Hose Clamp offers a durable and stable clamping force which provide a long lasting hose connection for a wide array of marine, industrial, automotive and household applications.

One-piece, 316L stainless steel screw cage

316L screw with hexagonal screw head and screw driver slot

316L embossed band

Rolled edges

Non-perforated worm drive

Smooth inside



LOWER IDLE TORQUE TEST*

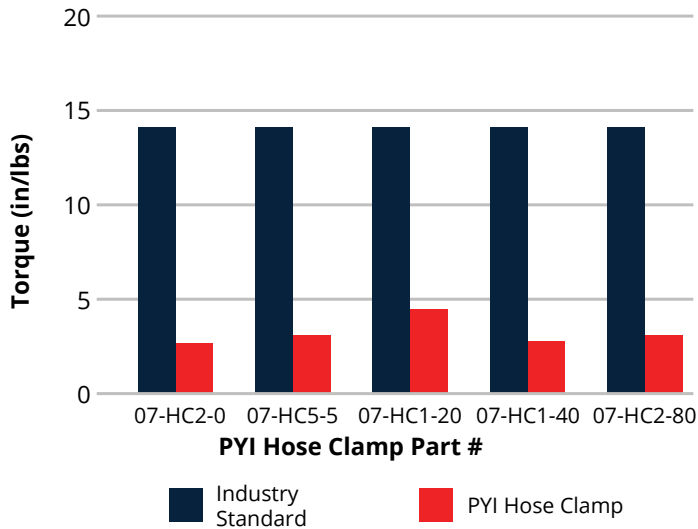

DESTRUCTIVE-TURNING TORQUE TEST**

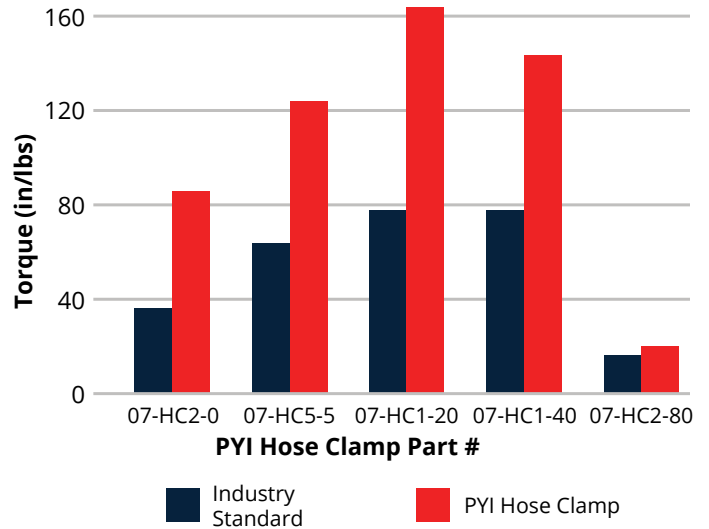

* The Lower Idle Torque is the amount of torque required to twist the screw to tighten the clamp (lower is better).

** The Destructive Turning Torque Test measures how much force is required to break the hose clamp (higher is better).



CERTIFICATIONS

PYI Hose Clamps are manufactured in a facility that has earned the BSI Kitemark™ and is ISO 9001:2015 certified by Bureau Veritas.



DURABLE DESIGN

The screw cage utilizes a one-piece design capable of withstanding high tightening torque and internal hose pressure. The screw cage is pressed with a riveting machine that uses 60 tons of pressure to form the metal and the band together resulting in an extremely durable solution. The clamp can be hand tightened to over 135 in/lbs. without the screw slipping or the cage becoming deformed.



SPECIFICATIONS

PART #	A (Min-Max Hose Diameter)	B	C	D	E	RECOMMENDED TORQUE
07-HC1-2	0.37"-0.47" (9.5-12mm)	0.75" (19mm)	0.37" (9.5mm)	0.39" (10.0mm)	0.48" (12.3mm)	30.1 in/lbs
07-HC1-6	0.43"-0.63" (11-16mm)	0.75" (19mm)	0.37" (9.5mm)	0.39" (10.0mm)	0.48" (12.3mm)	30.1 in/lbs
07-HC2-0	0.50"-0.79" (13-20mm)	0.75" (19mm)	0.37" (9.5mm)	0.39" (10.0mm)	0.48" (12.3mm)	30.1 in/lbs
07-HC2-2	0.63"-0.87" (16-22mm)	0.94" (24mm)	0.47" (12.0mm)	0.50" (12.5mm)	0.58" (14.65mm)	37.2 in/lbs
07-HC2-5	0.71"-0.98" (18-25mm)	0.94" (24mm)	0.47" (12.0mm)	0.50" (12.5mm)	0.58" (14.65mm)	37.2 in/lbs
07-HC3-0	0.87"-1.18" (22-30mm)	0.94" (24mm)	0.47" (12.0mm)	0.50" (12.5mm)	0.58" (14.65mm)	45.1 in/lbs
07-HC3-5	0.98"-1.38" (25-35mm)	0.94" (24mm)	0.47" (12.0mm)	0.50" (12.5mm)	0.58" (14.65mm)	45.1 in/lbs
07-HC4-0	1.18"-1.57" (30-40mm)	0.94" (24mm)	0.47" (12.0mm)	0.50" (12.5mm)	0.58" (14.65mm)	45.1 in/lbs
07-HC4-5	1.38"-1.78" (35-45mm)	0.94" (24mm)	0.47" (12.0mm)	0.50" (12.5mm)	0.58" (14.65mm)	45.1 in/lbs
07-HC5-0	1.38"-1.97" (35-50mm)	1.30" (33mm)	0.47" (12.0mm)	0.50" (12.5mm)	0.58" (14.65mm)	52.2 in/lbs
07-HC5-5	1.57"-2.16" (40-55mm)	1.30" (33mm)	0.47" (12.0mm)	0.50" (12.5mm)	0.58" (14.65mm)	52.2 in/lbs
07-HC6-0	1.78"-2.36" (45-60mm)	1.30" (33mm)	0.47" (12.0mm)	0.50" (12.5mm)	0.58" (14.65mm)	52.2 in/lbs
07-HC7-0	2.17"-2.76" (55-70mm)	1.30" (33mm)	0.47" (12.0mm)	0.50" (12.5mm)	0.58" (14.65mm)	60.2 in/lbs
07-HC8-0	2.36"-3.15" (60-80mm)	1.30" (33mm)	0.47" (12.0mm)	0.50" (12.5mm)	0.58" (14.65mm)	60.2 in/lbs
07-HC9-0	2.76"-3.54" (70-90mm)	1.30" (33mm)	0.47" (12.0mm)	0.50" (12.5mm)	0.58" (14.65mm)	60.2 in/lbs
07-HC1-00	3.35"-3.94" (85-100mm)	1.30" (33mm)	0.47" (12.0mm)	0.50" (12.5mm)	0.58" (14.65mm)	60.2 in/lbs
07-HC1-20	3.54"-4.72" (90-120mm)	1.30" (33mm)	0.47" (12.0mm)	0.50" (12.5mm)	0.58" (14.65mm)	60.2 in/lbs
07-HC1-25	3.94"-4.92" (100-125mm)	1.30" (33mm)	0.47" (12.0mm)	0.50" (12.5mm)	0.58" (14.65mm)	60.2 in/lbs
07-HC1-40	4.72"-5.51" (120-140mm)	1.30" (33mm)	0.47" (12.0mm)	0.50" (12.5mm)	0.58" (14.65mm)	60.2 in/lbs
07-HC1-50	5.11"-5.91" (130-150mm)	1.30" (33mm)	0.47" (12.0mm)	0.50" (12.5mm)	0.58" (14.65mm)	60.2 in/lbs
07-HC1-60	5.12"-6.30" (130-160mm)	1.30" (33mm)	0.47" (12.0mm)	0.50" (12.5mm)	0.58" (14.65mm)	52.2 in/lbs
07-HC1-80	5.91"-7.10" (150-180mm)	1.30" (33mm)	0.47" (12.0mm)	0.50" (12.5mm)	0.58" (14.65mm)	52.2 in/lbs
07-HC2-00	6.70"-7.87" (170-200mm)	1.30" (33mm)	0.47" (12.0mm)	0.50" (12.5mm)	0.58" (14.65mm)	52.2 in/lbs
07-HC2-30	7.48"-9.05" (190-230mm)	1.30" (33mm)	0.47" (12.0mm)	0.50" (12.5mm)	0.58" (14.65mm)	52.2 in/lbs
07-HC2-50	8.66"-9.84" (220-250mm)	1.30" (33mm)	0.47" (12.0mm)	0.50" (12.5mm)	0.58" (14.65mm)	52.2 in/lbs
07-HC2-80	9.45"-11.02" (240-280mm)	1.30" (33mm)	0.47" (12.0mm)	0.50" (12.5mm)	0.58" (14.65mm)	52.2 in/lbs
07-HC3-00	10.63"-11.80" (270-300mm)	1.30" (33mm)	0.47" (12.0mm)	0.50" (12.5mm)	0.58" (14.65mm)	52.2 in/lbs
07-HC3-30	11.42"-13" (290-330mm)	1.30" (33mm)	0.47" (12.0mm)	0.50" (12.5mm)	0.58" (14.65mm)	52.2 in/lbs
07-HC3-60	12.60"-14.17" (320-360mm)	1.30" (33mm)	0.47" (12.0mm)	0.50" (12.5mm)	0.58" (14.65mm)	52.2 in/lbs
07-HC3-80	13.78"-14.96" (350-380mm)	1.30" (33mm)	0.47" (12.0mm)	0.50" (12.5mm)	0.58" (14.65mm)	52.2 in/lbs

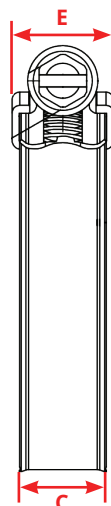
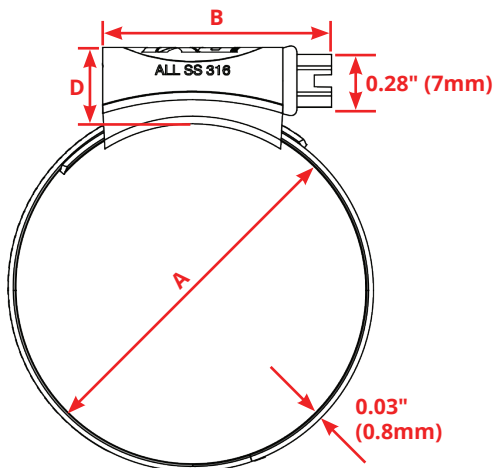

CLAMP JACKET

Clamp Jackets protects users from cuts and scrapes caused by the sharp ends of hose clamps.

Made out of durable EPDM rubber, the unique sleeve design allows the Clamp Jacket to slip over the tail of a hose clamp to provide a worker protection from cuts and abrasion from exposed clamp tails. The Clamp Jacket is ideal for a multitude of projects including marine, automotive, industrial, military and even around the house.



TECHNICAL SPECIFICATIONS

Temperature Range	-65°F to +300°F
Material Durometer	70+ / -5 (Shore A)
Tensile Strength	14.3 MPa

PART NUMBERS



QTY	5/16"	1/2"	1/4"
25	CJ-516-25	CJ-12-25	CJ-T14-25
100	CJ-516-100	CJ-12-100	CJ-T14-100
900	CJ-516-25C	CJ-12-25C	CJ-T14-25C
1,200	CJ-516-100-C	CJ-12-100C	CJ-T14-100C
2,500	CJ-516-2-5K	CJ-12-2-5K	CJ-T14-2-5K
10,000	CJ-516-10K	CJ-12-10K	CJ-T14-10K
100,00	CJ-516-100K	CJ-12-100K	CJ-T14-100K

HOSE CLAMP STYLE FEATURES



T-BOLT CLAMP STYLE FEATURES

Simply slides on 1/4" threads. Protects threads as well as the user.

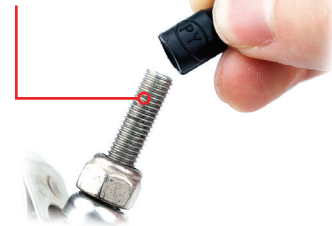

No more hassling with fingers sliding off, indents for superior grip when installing and removing.



APPLICATIONS

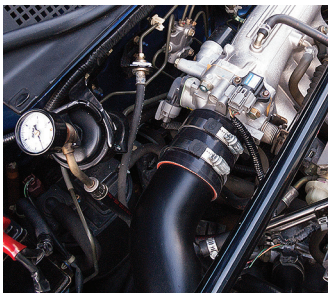

AUTOMOTIVE

Dress up your engine bay with Clamp Jackets. Also protects you from cuts and scrapes while working on your car.

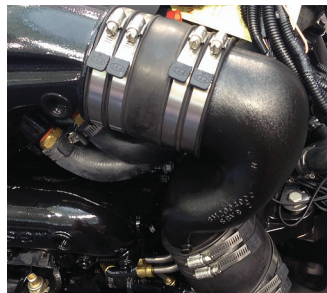

MARINE

Clamp Jackets are great to use on your boat. Make working on your boat less painful!



INDUSTRIAL

Protect your workers from possible injury with our hose clamp protectors.



HOUSEHOLD

Make working around the house pain free!

PRODUCT CROSS REFERENCE GUIDE

PYI HOSE CLAMP PART #	RANGE OF ADJUSTMENT	ABA	AWAB	MURRAY	SAE	TRIDON
07-HC1-2	0.37"-0.47" (9.5-12mm)	-	-	EBL12x012SS	3	-
07-HC1-6	0.43"-0.63" (11-16mm)	-	316017	EBL12x016SS	4	-
07-HC2-0	0.50"-0.79" (13-20mm)	0813 4003 020	316020	EBL12x022SS	6	-
07-HC2-2	0.63"-0.87" (16-22mm)	0813 4003 020	316024	EBL12x022SS	8	53415-0027
07-HC2-5	0.71"-0.98" (18-25mm)	0813 4003 024	316028	EBL12x027SS	10	53415-0027
07-HC3-0	0.87"-1.18" (22-30mm)	0813 4003 027	316032	EBL12x032SS	12	53415-0032
07-HC3-5	0.98"-1.38" (25-35mm)	0813 4003 032	316038	EBL12x040SS	16	53415-0040
07-HC4-0	1.18"-1.57" (30-40mm)	0813 4003 038	316044	EBL12x045SS	20	53415-0045
07-HC4-5	1.38"-1.78" (35-45mm)	0813 4003 038	316044	EBL12x050SS	24	53415-0045
07-HC5-0	1.38"-1.97" (35-50mm)	0813 4003 044	316050	EBL12x050SS	28	53415-0050
07-HC5-5	1.57"-2.16" (40-55mm)	0813 4003 050	316057	EBL12x060SS	32	53415-0060
07-HC6-0	1.78"-2.36" (45-60mm)	0813 4003 050	316064	EBL12x060SS	36	53415-0060
07-HC7-0	2.17"-2.76" (55-70mm)	0813 4003 067	316070	EBL12x070SS	40	53415-0075
07-HC8-0	2.36"-3.15" (60-80mm)	0813 4003 077	316083	EBL12x080SS	44	53415-0080
07-HC9-0	2.76"-3.54" (70-90mm)	0813 4003 077	316095	EBL12x090SS	48	53415-0090
07-HC1-00	3.35"-3.94" (85-100mm)	0813 4003 100	316102	EBL12x100SS	56	53415-0100
07-HC1-20	3.54"-4.72" (90-120mm)	0813 4003 100	316127	EBL12x110SS	64	53415-0110
07-HC1-25	3.94"-4.92" (100-125mm)	0813 4003 121	316127	EBL12x120SS	72	53415-0120
07-HC1-40	4.72"-5.51" (120-140mm)	0813 4003 121	316140	EBL12x140SS	80	53415-0140
07-HC1-50	5.11"-5.91" (130-150mm)	0813 4003 148	316152	EBL12x150SS	88	53415-0150
07-HC1-60	5.12"-6.30" (130-160mm)	0813 4003 148	316165	EBL12x160SS	96	53415-0160
07-HC1-80	5.91"-7.10" (150-180mm)	0813 4003 165	316178	-	104	-
07-HC2-00	6.70"-7.87" (170-200mm)	0813 4003 190	316203	-	120	-
07-HC2-30	7.48"-9.05" (190-230mm)	0813 4003 216	316232	-	138	-
07-HC2-50	8.66"-9.84" (220-250mm)	0813 4003 241	316257	-	154	-
07-HC2-80	9.45"-11.02" (240-280mm)	0813 4003 267	316283	-	170	-
07-HC3-00	10.63"-11.80" (270-300mm)	0813 4003 292	316308	-	186	-
07-HC3-30	11.42"-13" (290-330mm)	-	-	-	208	-
07-HC3-60	12.60"-14.17" (320-360mm)	-	-	-	224	-
07-HC3-80	13.78"-14.96" (350-380mm)	-	-	-	236	-

* Actual size ranges may vary

HOSE CLAMP ACCESSORIES



FLEXIBLE HOSE CLAMP DRIVER

The flexible shaft allows for access in tight spaces such as plumbing repair, automotive, marine engines, etc. The socket fits all PYI Hose Clamps or any hose clamp with 7mm screw heads.



www.pyihoseclamp.com

U.S. HEADQUARTERS

12532 Beverly Park Road
Lynnwood, WA 98087
(425) 355-3669
info@pyiinc.com
www.pyiinc.com

EUROPEAN HEADQUARTERS

ZI du Capitou, 85 rue Louis Lepine
83600 Frejus - France
+33 4 94 5327 70
info@seaviewprogress.com
www.seaviewprogress.com

UK OFFICE

+44 (0) 7393 556751
simon.wood@seaviewprogress.co.uk
www.seaviewprogress.com

Get social with us!

